

# ● Metalastik® type D series, Super D & DX mountings



## Metalastik® type D series

Metalastik® D Series Mountings are suitable for the suspension of heavy equipment or machinery where insulation against low frequency vibration is required with the additional benefit of excellent high frequency acoustic attenuation.

## Applications/Features

The relatively large rubber volume ensures high degrees of insulation against low frequency disturbing vibrations. Differing stiffness rates in the two horizontal modes enables suspension characteristics to be optimized by appropriate orientation of the mountings.

The mountings can be used in conjunction with additional bonded rubber buffers to limit movement of the suspended equipment under shock loading.

Parts can be supplied to meet naval specification requirements and also with plain flanges for drilling by the customer.

Applications include :

- Medium speed marine propulsion engines
- Generator sets
- Gearboxes
- Pumps
- Compressors and refrigeration systems

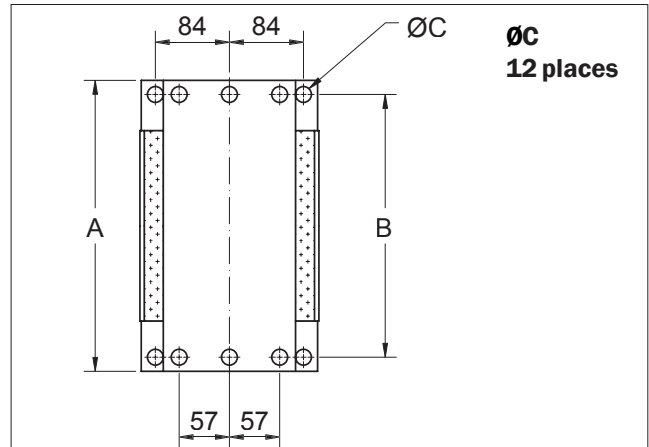
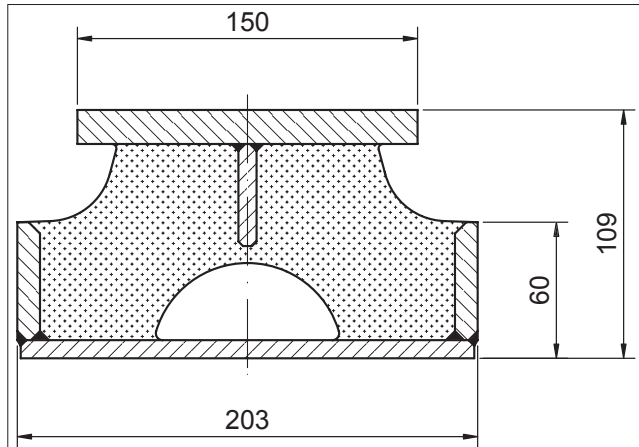

## Dseries

All dimensions in mm

Product No.	A	B	C	Weight (kg)	Rubber Hardness	Vertical Static Stiffness (N/mm)	Vertical Dynamic Stiffness (N/mm)	Maximum Static Load (kN)
17-1601	330	298	18	15	45	880	1010	14.2
					55	1315	1640	21
					65	1960	2650	31.4
17-1602	267	235	14	12	45	805	920	12.75
					55	1200	1520	19
					65	1710	2320	27.5
17-1603	210	178	14	9	45	410	470	6.6
					55	610	755	9.5
					65	900	1215	14.2

## Nominal Stiffness Ratios

Vertical	Lateral	Longitudinal
1	0.95	0.17

# ● Metalastik® type D series, Super D & DX mountings

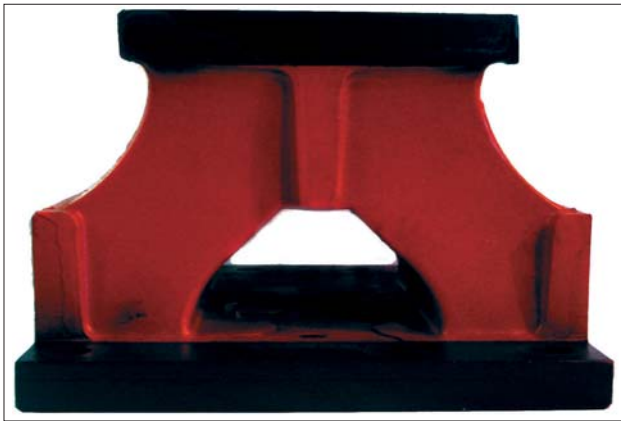

## Metalastik® type Super D

The "Super D" mounting range is designed primarily for heavy marine installations requiring increased shock capacity. These mountings operate at a nominal static deflection of 23 mm and can accommodate up to 50 mm shock excursions in any direction.

Buffer 15-3671 with low friction contact pad is often used with Super D mounts to limit movement under extreme shock forces, particularly as a non metallic rake and ramming stop. Please refer to page 4 for further information on buffer arrangements.

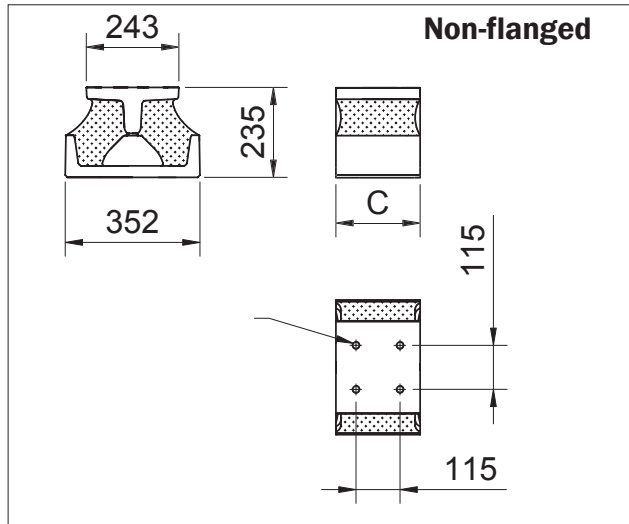
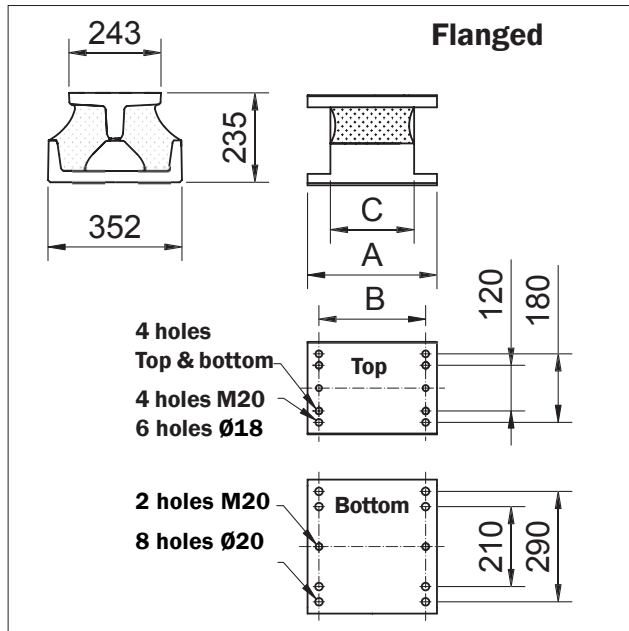

## Super D

All dimensions in mm

Product No.	A	B	C	Mass Weight (kg)	Rubber Hardn.	Vertical Static Stiffness (N/mm)	Vertical Dynamic Stiffness (N/mm)	Max Static Load (kN)
<b>Flanged type</b>								
17-1736	340	280	220	65	45	620	710	14.2
					55	920	1160	21
					65	1375	1965	31.5
17-1737	410	350	290	81	45	835	960	19
					55	1180	1275	29.5
					65	1960	2650	44
17-1738	480	420	360	97	45	1325	1520	30.5
					55	1960	2450	45
					65	2940	3975	67.8
<b>Non-flanged type</b>								
17-1661			220	48.5	45	620	710	14.2
					55	920	1160	21
					65	1375	1965	31.5
17-1662			290	64	45	835	960	19
					55	1180	1275	29.5
					65	1960	2650	44
17-1663			360	80	45	1325	1520	30.5
					55	1960	2450	45
					65	2940	3975	67.8

## Nominal Stiffness Ratios

Vertical	Lateral	Longitudinal
1	1	0.22